

MARC 5 Series Overview

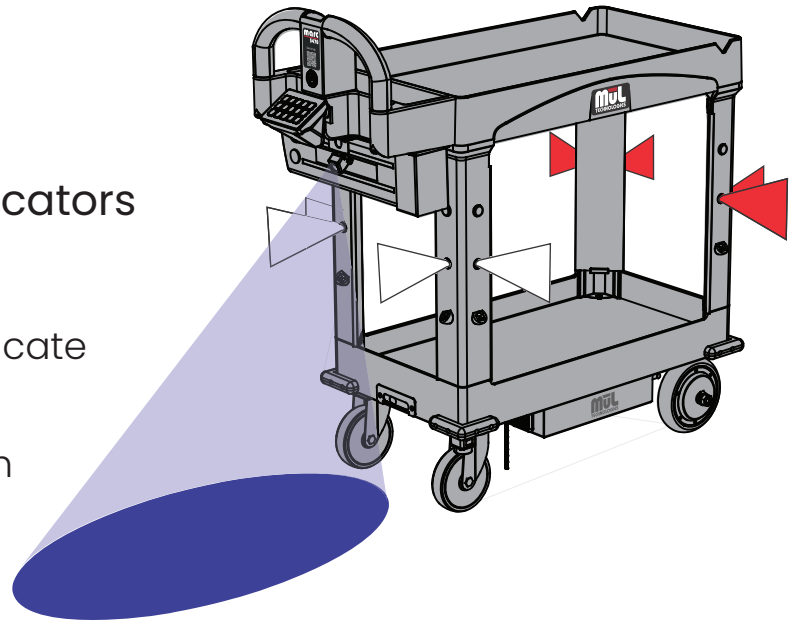

Wi-Fi Free

- Operate in any facility in under 10 minutes!
- Requires no infrastructure changes – no need for IT involvement.
- Truly self-guided autonomous operation
- Eliminates 'lost robot' syndrome with CPA™ technology.
- Avoids obstacles in real time with continuous route planning.



Highly Visible with Intuitive Indicators

- Leading blue light for visibility.
- Headlight/Taillight to instantly indicate direction of travel at glance.
- Highly approachable robotics with high team adoption rates.



EZ-Go Navigation™ system

- No training needed for operation.
- No complex map interfacing.
- Extremely simple programming – push cart anywhere and press a location button for 3 seconds and it instantly becomes a known destination.

SYSTEM OVERVIEW

MūL Mobile Autonomous Robotic Carts are designed with simplicity as the core principle. All of our products are built using robust commercial components, and are designed to be extremely approachable by the people who will use it every day.

We also offer extremely reasonable costs, resulting in the fastest ROI of any AMR on the market. Keep your staff doing the value-add work you hired them for!

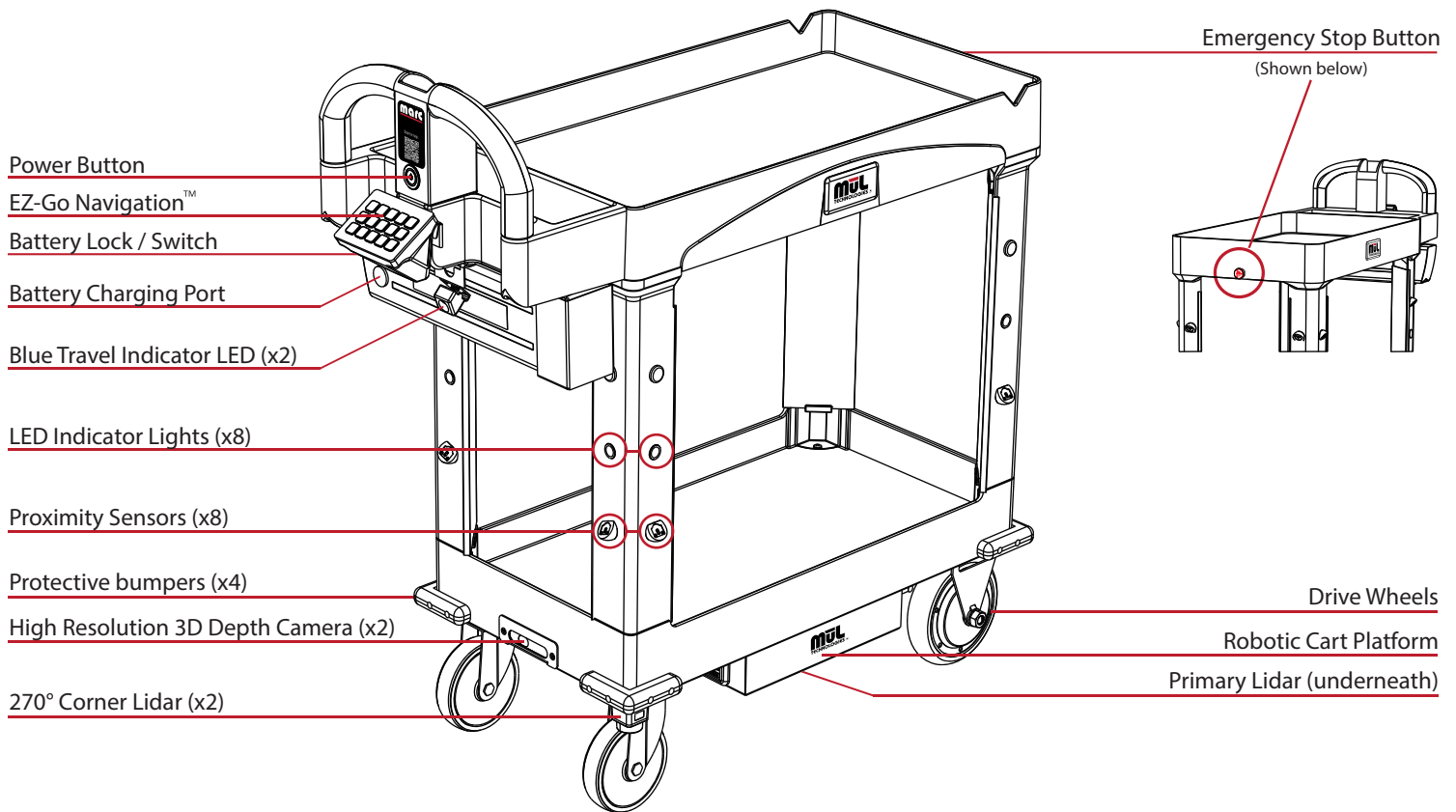

DIMENSIONS

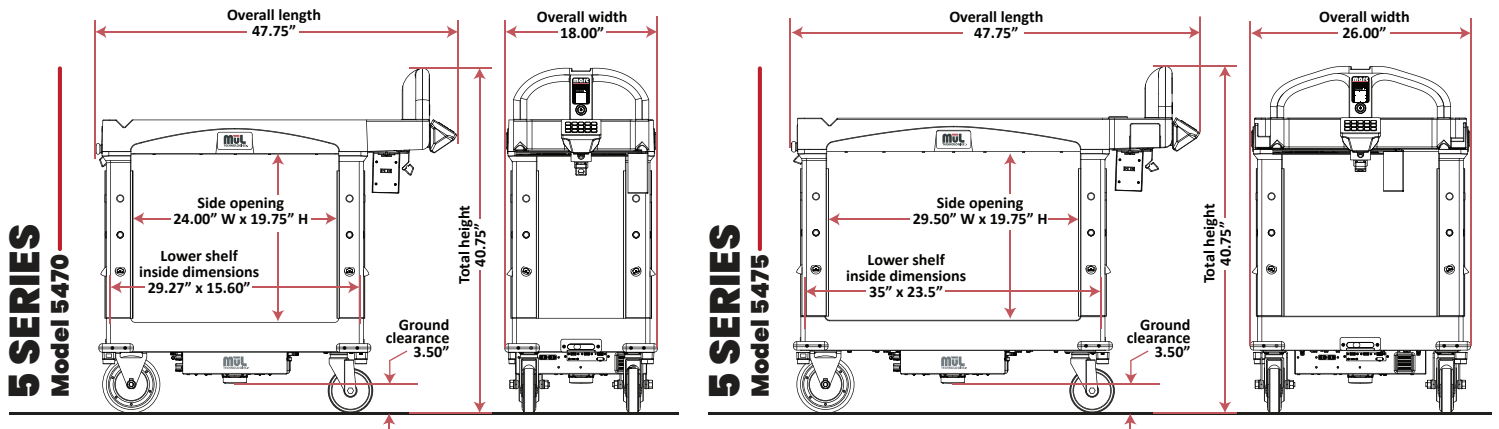

SMALL CART DIMENSIONS

LARGE CART DIMENSIONS

SENSOR OVERVIEW

- High resolution 3D depth cameras allow MARC to see at extreme angles and operate safely.
- Three high resolution LIDAR units scan the environment in realtime to build a completely independent map that is used to navigate through an ever-changing facility.
- 8 proximity sensors create an anti-collision system with 360° view of the area near the cart.
- Internal 3-axis digital gyroscope combined with a 3-axis accelerometer for measuring tilt, acceleration and shock.

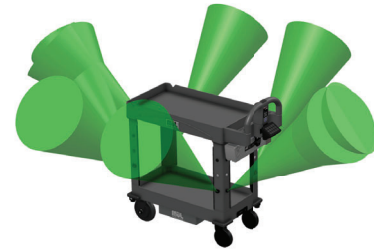
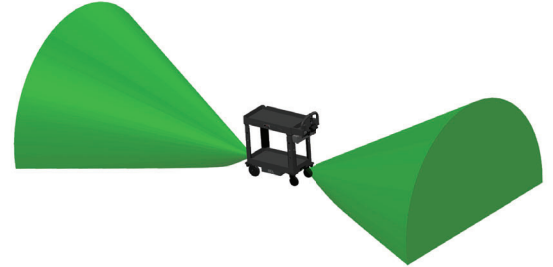
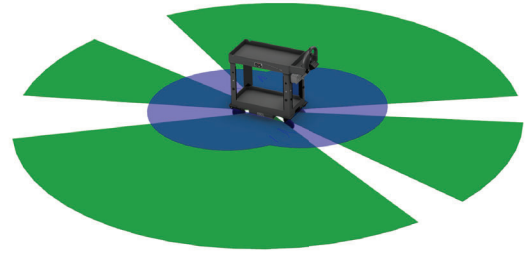

SENSOR PARAMETERS:

- Primary LIDAR scans 360° at 32000 samples per second measuring at a distance of 25m with 1° angular resolution and 13mm distance resolution.
- Auxiliary LIDARs (X2) scan 270° at 4500 samples per second measuring at a distance of 3m with 1° angular resolution, 15mm distance resolution
- 8 proximity sensors with 1m range and 1mm distance resolution.
- Dual 3D cameras with up to 1280 × 720 active stereo depth resolution at up to 90 fps. Active IR stereo depth technology with a field of view of 87°±3° × 58°±1° × 95°±3°.

EXAMPLE POINT-TO-POINT NAVIGATION

1 Manufacturing

As products are manufactured, they are loaded and operator presses 2 to send the cart autonomously to inventory area.

2 Inventory

Products are pulled from stock and loaded and puller presses 3 to send the cart to final inspection.

3 Final Inspection

Once products are ready for shipment, inspector presses 4 to send loaded cart to shipping area.

4 Shipping

Shipment is loaded onto truck and once the cart is empty, loader presses button for the destinations where they would like to send the robotic cart to begin the next task.



SYSTEM DETAILS

Key detailed specifications:

- Supported temperature range from 5° to 45°C (41° - 110°F) in non-condensing humidity.
- 3.5" (8.9 cm) of ground clearance.
- All metal components are heavy duty and coated for corrosion protection.
- Electrically isolated motors allow the cart to be easily pushed manually.
- Push-to-kill red emergency stop button for added safety.
- Illuminated ON/OFF button for clear visibility.
- 220lb / 100kg maximum payload in autonomous mode.
- Reverse voltage, over voltage and short circuit protections.
- Less than 2 minutes from power-on to ready state.
- High resolution encoders attached to each motor.
- Brushless DC motors with independent motor controllers.
- Software includes environment mapping, planning, navigation, obstacle avoidance and control while running as part of a real time operating system.
- Speaker provides audio communication of status in spoken words.
- RGB, high bright LEDs for visual indication of events, status and issues.
- 15-key keypad with integrated graphical displays behind each key for clear identification.
- Automatic real time diagnostics and visual cues for proximity sensors, LEDs and battery level.
- Operates in forward and reverse direction.

Battery pack and charger information:

- Long battery life - 8 hours (20Ah) and 12-hours (30Ah) under typical usage.
- 24V lithium-ion battery pack with internal BMS (battery management system).
- Duty cycle of 800 charge / discharge cycles.
- 100-240VAC battery pack charger that uses standard outlet.
- Keyed switch for securing battery pack in place and providing power.
- Integrated battery level indicator panel.

CONTACT US

email: contact@multechnologies.com

Phone: 262.242.8830

Address: 10202 North Enterprise Drive, Mequon WI 53092

Web: www.multechnologies.com