

MARC Series 4

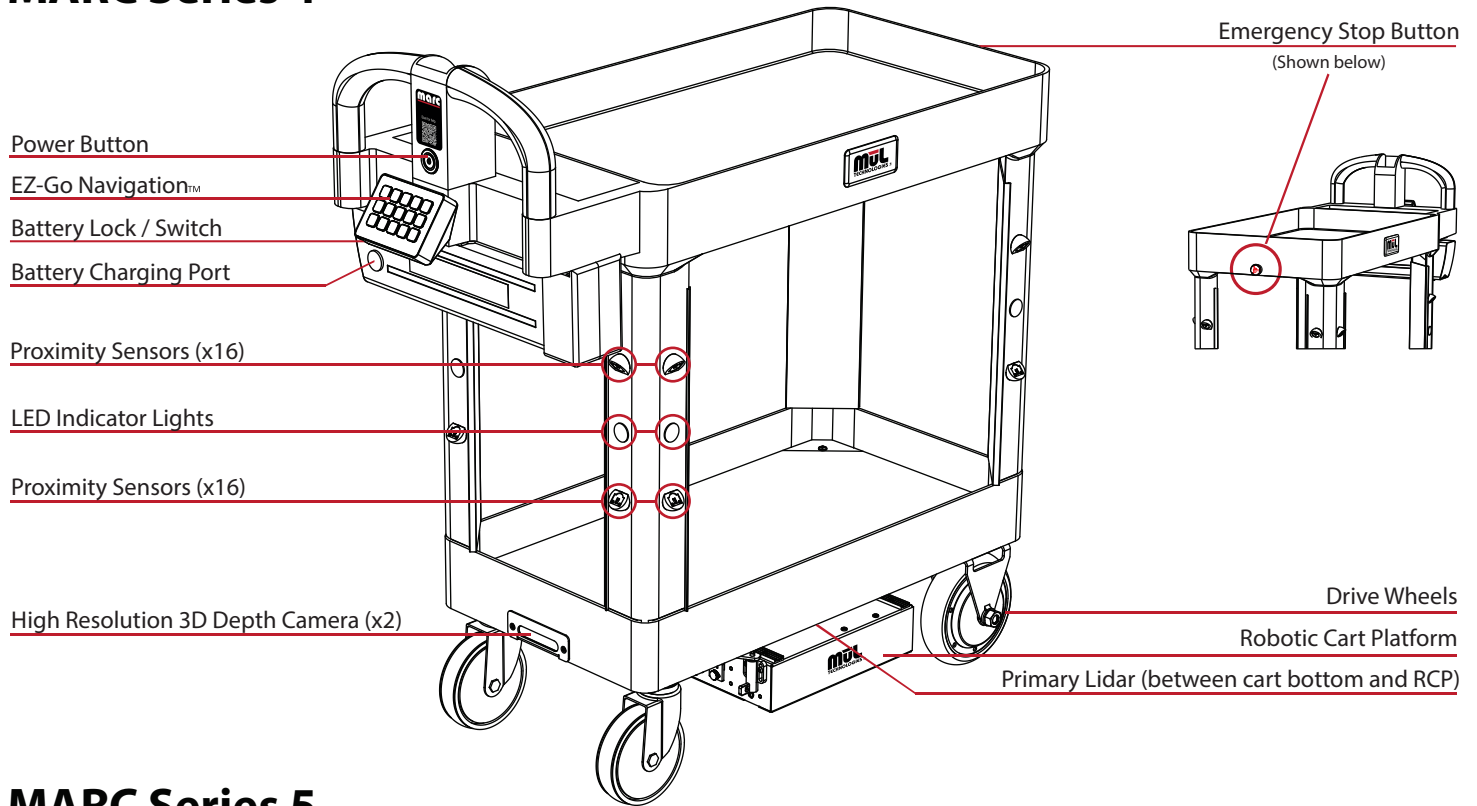

MARC Series 5

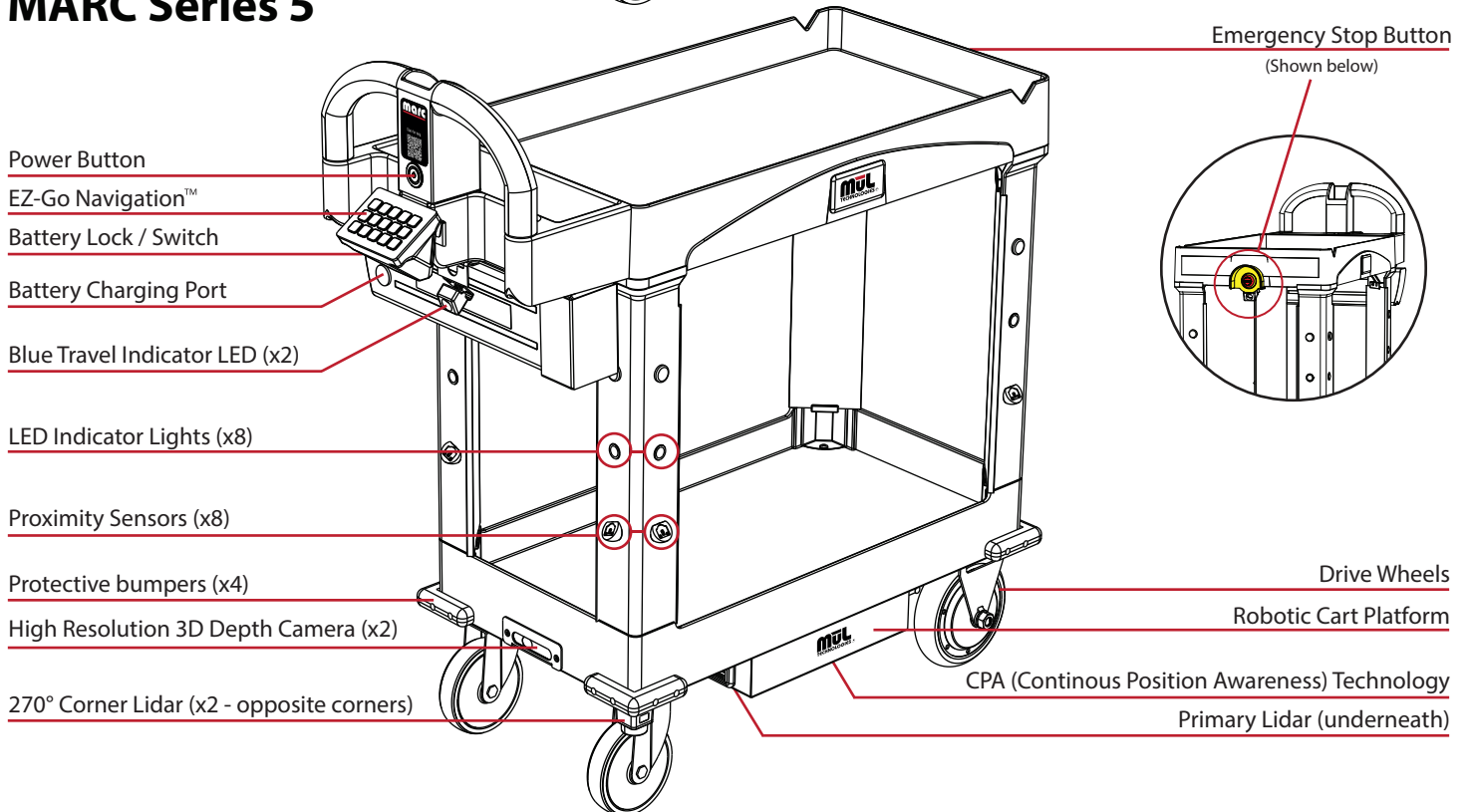

Model Feature Comparison

Feature	Series 5	Series 4
No Wi-Fi or other connection required - no need for IT!	✓	✓
Implementation in under 10 minutes - guaranteed!	✓	✓
EZ-Go Navigation™ for simple one-button programming and use.	✓	✓
Included swappable battery for continuous run time.	30Ah	20Ah
Power assist manual operation keys.	✓ *	✓
Looping Mode for constant travels from point to point	✓ *	✓
One-button-press programmable locations.	20*/10	13
High resolution Lidar for continuous mapping and object detection.	3	1
Maximum speed during autonomous movement	1 m/s	.5 m/s
Speaker for audio cues and beep-while-moving function.	90dB	60dB
CPA™ (Continuous Position Awareness).	✓	
Leading blue light for high visibility.	✓	
Corner bumpers for additional protection.	✓	
Access code to prevent accidental reprogramming.	✓ *	
Multilingual support for audio cues.	✓ *	
Access to cart statistics.	✓ *	
LV (Low Variance) mode – tighter route following	✓ *	
Warranty	1 year	1 year
Price	\$17,995	\$14,995
Optional Accessories		
ESD kit for prevention of electrostatic charge	\$995**	\$995**
Flag kit for increased visibility	\$95	\$95
Spare 30Ah swappable battery with up to 12 hours run time	\$1495	N/A
Optional LED light tower for increased visibility	\$249	N/A
USB ethernet adapter for software updates	\$99	N/A
Power Inverter	\$199**	N/A
Top lock box	Call**	Call
Video Screen version	Call**	N/A

* Certain Series 5 features are included in the Optional Software Package (OSP). All features are enabled for 13 months from date of purchase. A yearly access fee applies if you want to use the OSP after the initial 13 months. Please speak with the Mül sales team for details.

** Some optional accessories are factory installed and must be purchased on same order as carts being upgraded.